

MV-3403

Encoder	HEDS-9040 #B00
Voltage:	+5VDC ± 10%
Current:	100mA Max
Frequency:	0-100KHz
Temp.:	-40 - 100° C
Pulse:	1000

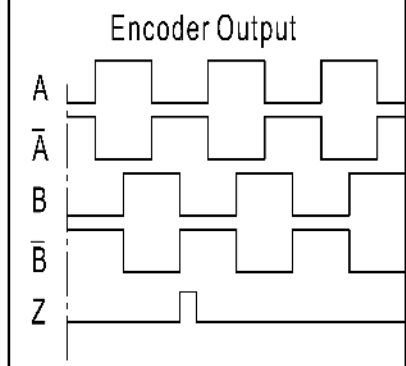

Rotation CCW from shaft side

1	Voltage	V	80
2	Phase	m	3
3	Pole	P	8
4			
5	Rated Torque	N.m	2.5
6	Rated Speed	rpm	3000 ± 10%
7	Rated Current	A	12 ± 20%
8	Peak Torque	N.m	7.5
9	Power	W	780
10	R(L-L)	ohm	
11	H(L-L)	mH	
12	Ke	V/Krpm	16

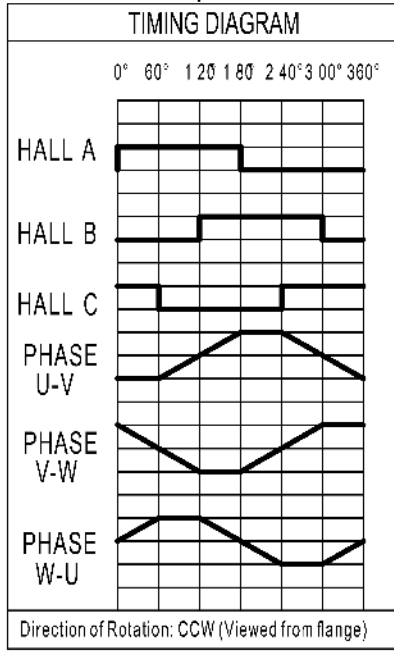
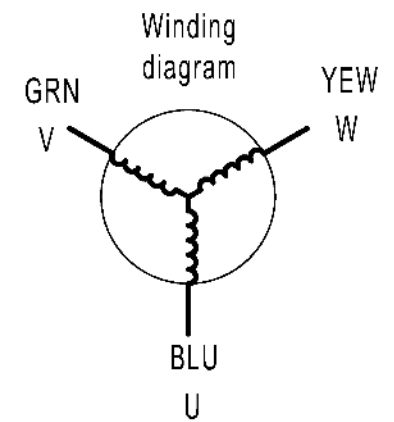
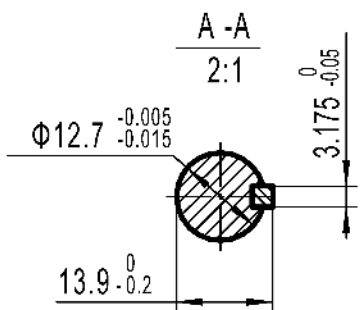
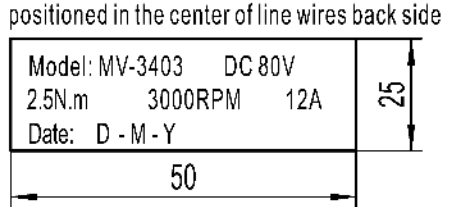
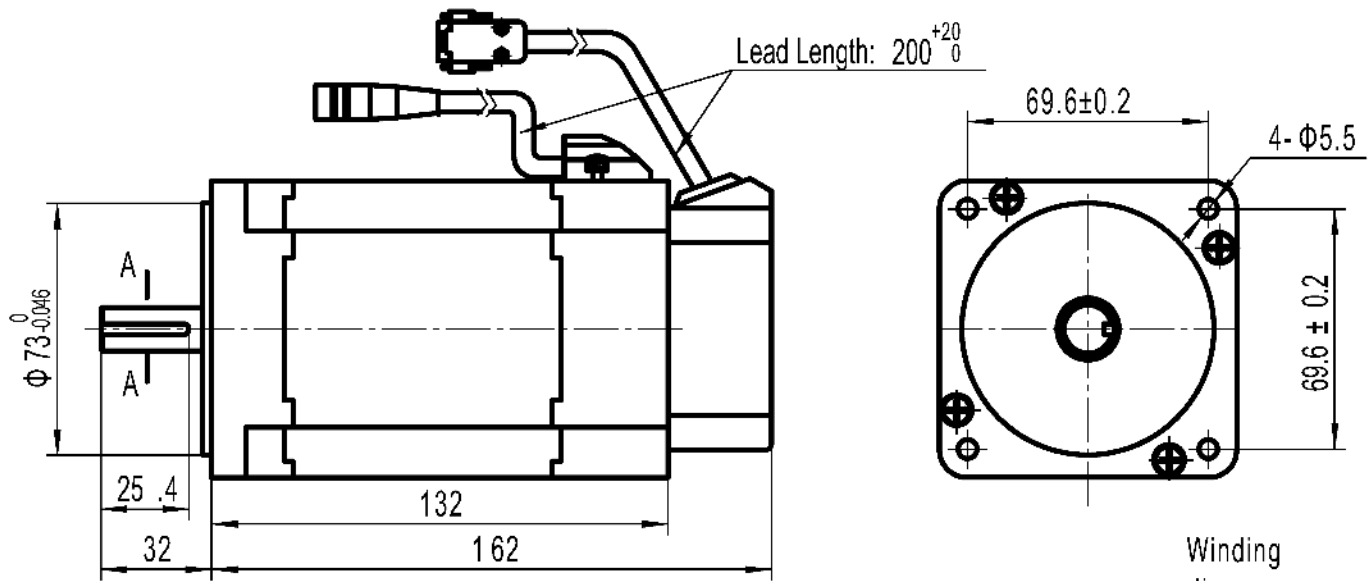

Encoder Connection										Motor		
1	2	3	4	5	9	10	11	12	13	1	2	3
Grey	Red	Violet	Pink	Orange	Blue	Black	White	Yellow	Green	Green	Blue	Yellow
HALL B	+5VDC	HALL A	B-	A-	HALL C	GND	Z	B	A	V	U	W

FLASHCUT CNC
CONTROL MADE SIMPLE